

HARMONIA

HELENE & MYRINA

SELF - SERVICE INTEGRAL COUNTERS





HARMONIA

SELF - SERVICE INTEGRAL COUNTERS



HARMONIA HELENE

Benefits & Specifications:

- Unique and stylish design
- High product visibility
- Harmonia Helene; mobile plug-in counter on castors.
- Harmonia Myrina; plug-in counter on foot.
- Sloped base deck to display products even if the counter is placed against the wall.
- User-friendly
- Small footprint with compact design
- Easy access and ergonomic design
- Easily adaptable to seasonal needs
- Low operating costs
- Simplified maintenance
- Wide range of future refrigerant options



HARMONIA MYRINA

Harmonia Helene & Myria

Dimensions (mm):

Height :1034

Length :1215

Depth : 1076

SYSTEM	OPERATING TEMP. °C	REFRIGERANT
PLUG-IN	+4 / +6	HC HFC blend HFC / HFO blend

HC: R290 / R1270 · HFC: R407A / R407F / R134a / R404A · HFC / HFO: R448A / R449A / R452A / R450A

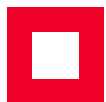

TECHNICAL DATA

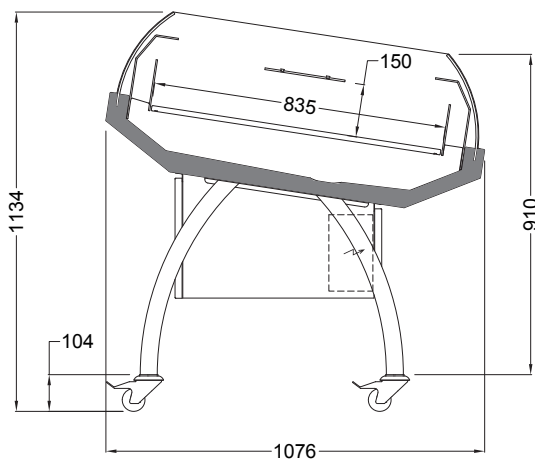

HARMONIA HELENE

Length mm | 1215

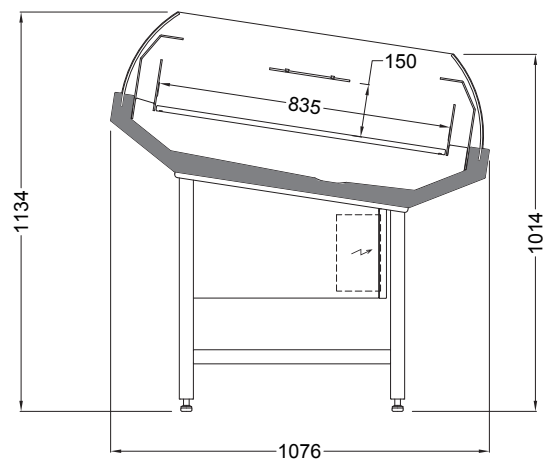

HARMONIA MYRIA

Length mm | 1215

YOUR
WORLD
OUR
WORLD